

10G SFP+ Active Optical Cable

Product Features

- Compliant with SFF-8472, SFF-8431, SFF-8432 and IEEE 802.3ae10GBASE-SR
- Up to 10.518 Gbps data rate
- VCSEL transmitter and PIN receiver for AOC
- Single +3.3V power supply
- Maximum power dissipation 1W
- Operation case temperature: 0 to 70°C
- Maximum link length of 300m on OM3 MMF
- RoHS6 compliance



Applications

- 10G Ethernet
- Enterprise & Data Center Networking & Storage
- High performance computing clusters

Absolute Maximum Ratings

Parameter	Unit	Min.	Typical	Max.	Notes
Storage Temperature	°C	-40		85	
Operating Relative Humidity	%	5		85	
Power Supply not Damaged Voltage	V	-0.5		3.6	
Damaged Input Optical Power	dBm			0	

Recommended Operating Conditions

Parameter	Unit	Min.	Typical	Max.	Notes
Operating Case Temperature	°C	0	20	70	
Power Supply Working Voltage	V	3.135	3.3	3.145	
Power Supply Current	mA			300	
Power Consumption	W			1	
Bit Rate	Gbps		10.3125	10.518	

Optical Characteristics

All performance is defined over the Recommended Operating Environment unless otherwise specified.

Parameter	Unit	Min.	Typical	Max.	Note
Transmitter					
TX Central Wavelength	nm	840	850	860	
Launch Optical Power (EOL)	dBm	-6.5		-1	
Launch Optical Power TX _{OFF}	dBm			-30	
Extinction Ratio	dB	3.5			1
Optical Return Loss Tolerance	dB			12	
Transmitter and Dispersion Penalty	dB			3.9	
Transmitter eye mask definition {X1, X2, X3, Y1, Y2, Y3}		{0.25, 0.40, 0.45, 0.25, 0.28, 0.40}			
Receiver					
RX Central Wavelength	nm	840	850	860	
Receiver sensitivity in OMA	dBm			-11.1	2
Stressed receiver sensitivity in OMA	dBm			-7.5	2
Saturation Input Optical Power	dBm			-1	
LOS De-assert	dBm			-12	
LOS Assert	dBm	-30			
LOS Hysteresis	dB	0.5			
Receiver reflectance	dBm			-12	

Note:

1. Measured with a PRBS 2³¹-1 test pattern @10.3125Gbps
2. Measured with a PRBS 2³¹-1 test pattern @10.3125Gbps, BER≤10⁻¹²

Electrical Specifications

Parameter	Unit	Min.	Typical	Max.	Note
Electrical					
Data Differential Impedance	Ω	90	100	110	
Data Input Swing Differential	mV	200		800	
Data Output Swing Differential	mV	300		800	
LVTTL Output High	V	2		V _{cc}	
LVTTL Output Low	V	0		0.4	
LVTTL Input High	V	2.0		V _{cc} +0.3	
LVTTL Input Low	V	-0.3		0.8	

PIN Function Definitions

Pin No.	Symbol	Level / Logic	Description	Note
1	VeeT		Module Transmitter Ground	1
2	Tx_Fault	LVTTTL-O	Module Transmitter Fault Indication	2
3	Tx_DIS	LVTTTL-I	Transmitter Disable; Active High Disable Transmitter Output	3
4	SDA	LVTTTL-I	2-Wire Serial Interface Data Line	
5	SCL	LVTTTL-I/O	2-Wire Serial Interface Clock	
6	MOD_ABS	LVTTTL-O	Module Absent, connected to ground in the module	2
7	RS0		Rate Select 0, optionally controls SFP28 module receiver	
8	RX_LOS	LVTTTL-O	Loss of Receiver Signal Indication	2
9	RS1		Rate Select 1, optionally controls SFP28 module transmitter	
10	VeeR		Module Receiver Ground	1
11	VeeR		Module Receiver Ground	1
12	RD-	CML-O	Receiver Inverted Data Output	
13	RD+	CML-O	Receiver Non-Inverted Data Output	
14	VeeR		Module Receiver Ground	1
15	VccR		Module Receiver 3.3V Supply	
16	VccT		Module Transmitter 3.3V Supply	
17	VeeT		Module Transmitter Ground	1
18	TD+	CML-I	Transmitter Non-Inverted Data Input	
19	TD-	CML-I	Transmitter Inverted Data Input	
20	VeeT		Module Transmitter Ground	1

Note:

1. The module ground pins are isolated from the module case.
2. The pins shall be pulled up with 4.7K-10Kohms to a voltage between 3.14V and 3.46V on host board.
3. The pin is pulled up to VCCT with a 4.7K-10KΩ resistor in the module.

Electrical Pad Layout

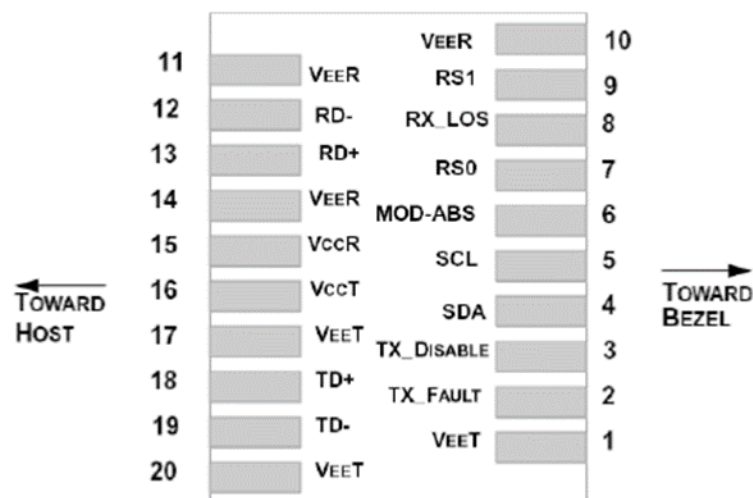

Typical Interface Circuit

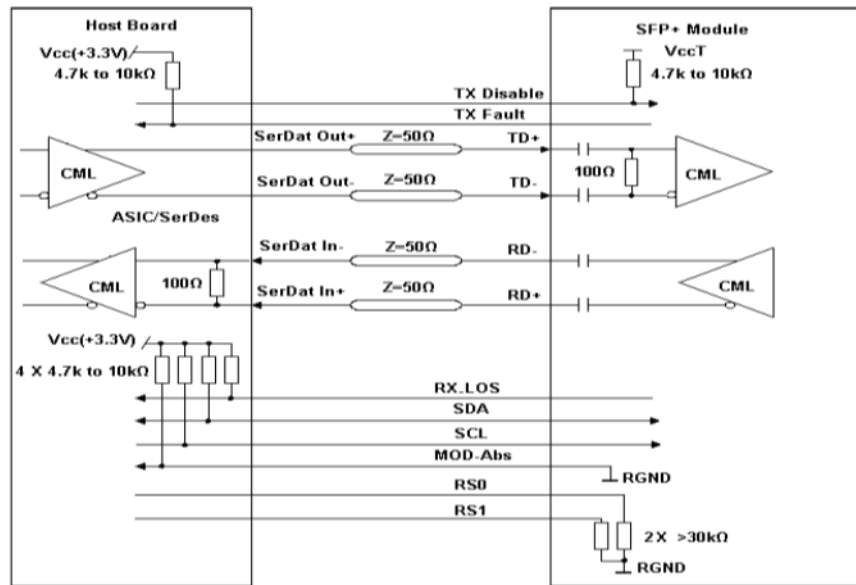

Mechanical Specifications

For detail mechanical information, please refer to the related document of SFF-8432.

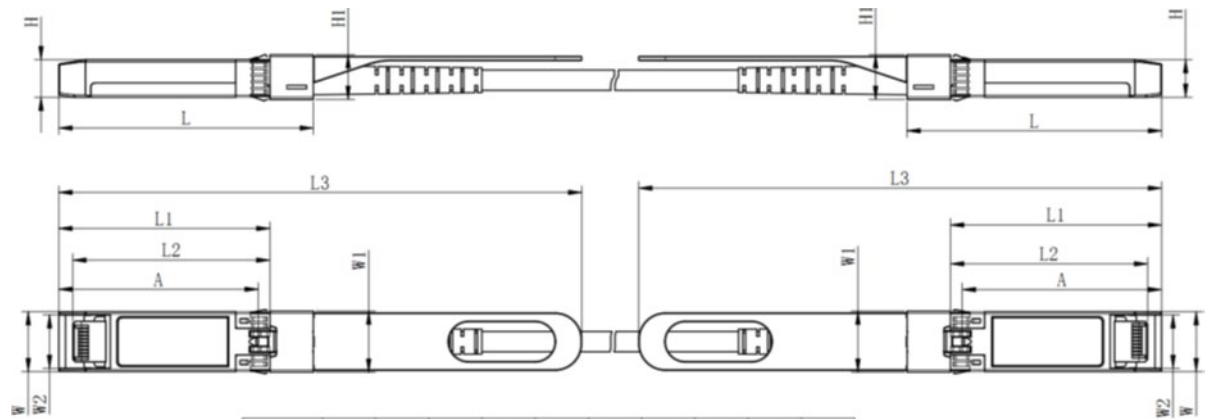

	L	L1	L2	L3	W	W1	W2	H	H1	A
MAX	57.6	47.7	44.55	119.9	13.8	14.0	12.3	8.7	10.3	45.25
Typical	57.4	47.5	44.35	117.9	13.55	13.8	12.1	8.5	10.1	45
MIN	57.2	47.3	44.15	115.9	13.3	13.6	11.9	8.4	9.9	44.65

EEPROM Information

The digital diagnostic memory map specific data field define as following. For detail EEPROM information, please refer to the related document of SFF 8472 Rev 12.0.

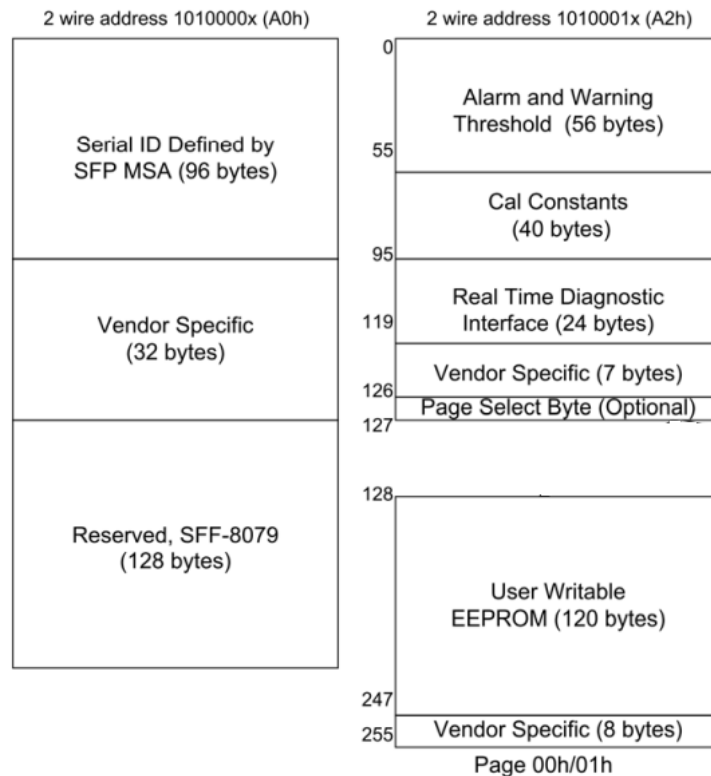

ESD

This 10G AOC is specified as ESD threshold 1kV for high speed data pins and 2kV for all other electrical input pins, tested per MIL-STD-883, Method 3015.4 /JESD22-A114-A (HBM). However, normal ESD precautions are still required during the handling of this module. This product is shipped in ESD protective packaging. It should be removed from the packaging and handled only in an ESD protected environment.

Laser Safety

This is a Class 1 Laser Product according to IEC 60825-1:2007. This product complies with 21 CFR 1040.10 and 1040.11 except for deviations pursuant to Laser Notice No. 50, dated (June 24, 2007).

Ordering Information

Ordering P/Ns	Description
D08899-SCCA-XXX	up to 400m, 850nm, 10G SFP+ to 10G SFP+ AOC

XXX	Cable (MMF) Length
001	001=1m
⋮	⋮
100	100=100m
⋮	⋮
300	300=300m

Contact Us**International Sales**Email: Sales@broadex-tech.co.uk

Tel: +44-1506-426021

Mobile: +44-7968-854124

China Sales

Tel: +86-573-82585881

Email: Sales@broadex-tech.com**Copyright © 2021 Broadex Technologies. All rights reserved**